



## **INTERPHARM TECHNOLOGIES THE COMPLETE PHARMACEUTICAL SERVICE**

---

**PHARMACEUTICAL FINISHED PRODUCT TECHNOLOGY**

**PHARMACEUTICAL EQUIPMENT + TECHNOLOGY**

**PHARMACEUTICAL FACTORY DESIGN**



## INTERPHARM PHARMACEUTICAL EQUIPMENT TECHNOLOGY CAPABILITIES + FACTORY DESIGN

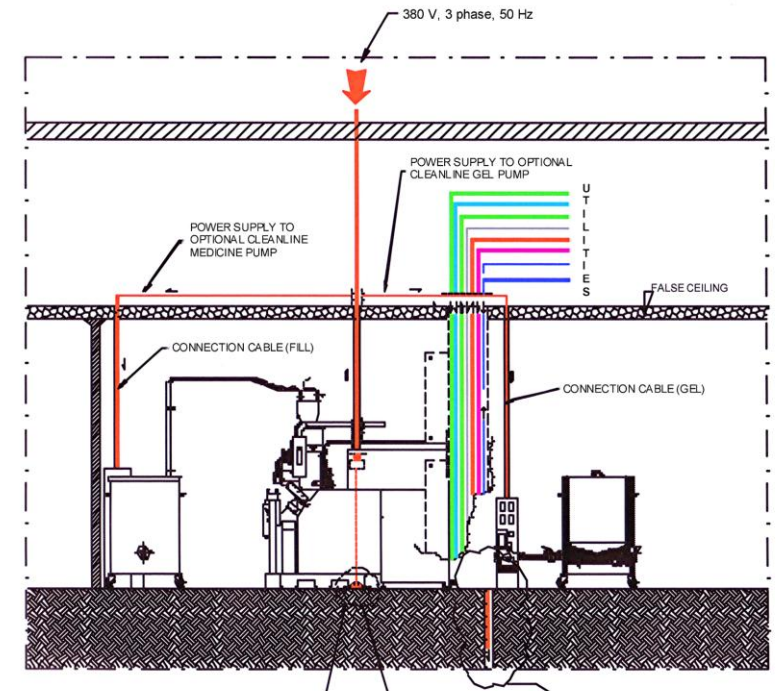

**Interpharm Technologies & its personnel have been at the forefront of supplying state of the art pharmaceutical equipment & technology, globally, for 3 decades.**

**Interpharm works closely with the multinational pharmaceutical, nutraceutical, cosmetic & paintball industries so that our clients receive comprehensive project backup with regard to factory layout & design, process technologies, & regulatory compliance.**



*Interpharm have supplied many types of pharmaceutical production & packaging equipment + factory designs + process technologies to companies around the World – including to Glaxo (left) & to the Government of China for anti-cancer product manufacture (above).*







**Interpharm has a partnership with SINOPHARM - the international division of the State Pharmaceutical Administration of China that controls all pharmaceutical organisations within the PRC.**

**Interpharm Technologies & Sinopharm co-operate to provide a wide range of pharmaceutical production & packaging equipment, supported by teams of both Chinese & Western pharmaceutical specialists who jointly provide the following, according to project requirements:**

- **proven production & packaging equipment**
- **factory designs (raw material & finished products)**
- **pharmaceutical process technology**
- **project start up & training teams**

***THE SINOPHARM HEADQUARTERS IN BEIJING (Right)***

***China has overall the largest pharmaceutical industry in the World & the largest pharmaceutical equipment manufacturing industry. China's pharmaceutical equipment industry has the input of aerospace technologists + Interpharm's highly experienced Western technologists.***

***80% of the World's electronics & computers are now made in China – including advanced control systems from Siemens, Fujitsu etc.***



## PRODUCTION EQUIPMENT + TECHNOLOGY

All Interpharm pharmaceutical equipment is supplied with validation & IQ / OQ documentation  
- to United States FDA standard. Full training + formulation technologies are available.

### 1) TABLET PRODUCTION



**LEFT: 76 – 122 station, D, B, BB, BBS high speed production (up to 1.1 million tabs/hour); RIGHT: flexible removable turret machine. A wide range of tablet machines is available from 16 - 122 stations + ancillary dedusters, vacuum loaders, punches & dies etc.**

## 2) TABLET COATING

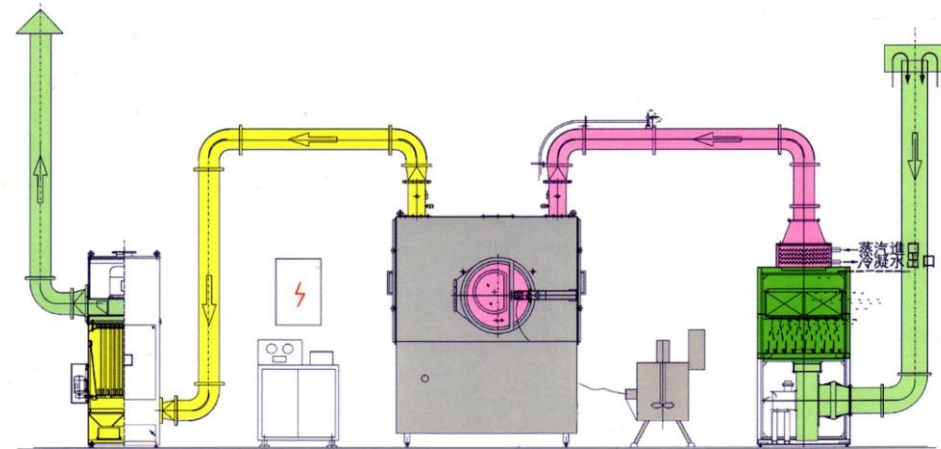
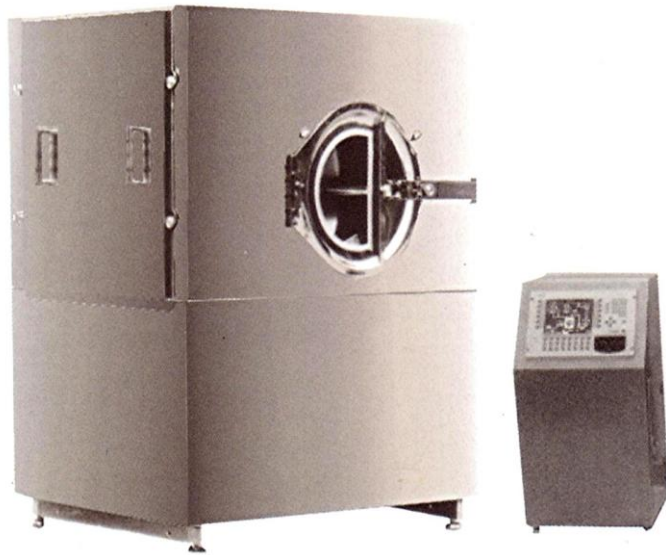

**Sugar coating + aqueous / film coating – 75 kg; 150 kg; 350 kg models.**

### 3) HARD CAPSULE FILLING



**A large range of automatic capsule fillers is available – filling capsules from size 00 – 5, with powders, granules & tablets. GMP, FDA validatable design – with a full range of ancillary equipment available for sorting, loading, polishing, dust collecting etc.**



#### 4) EMPTY HARD CAPSULE MANUFACTURE

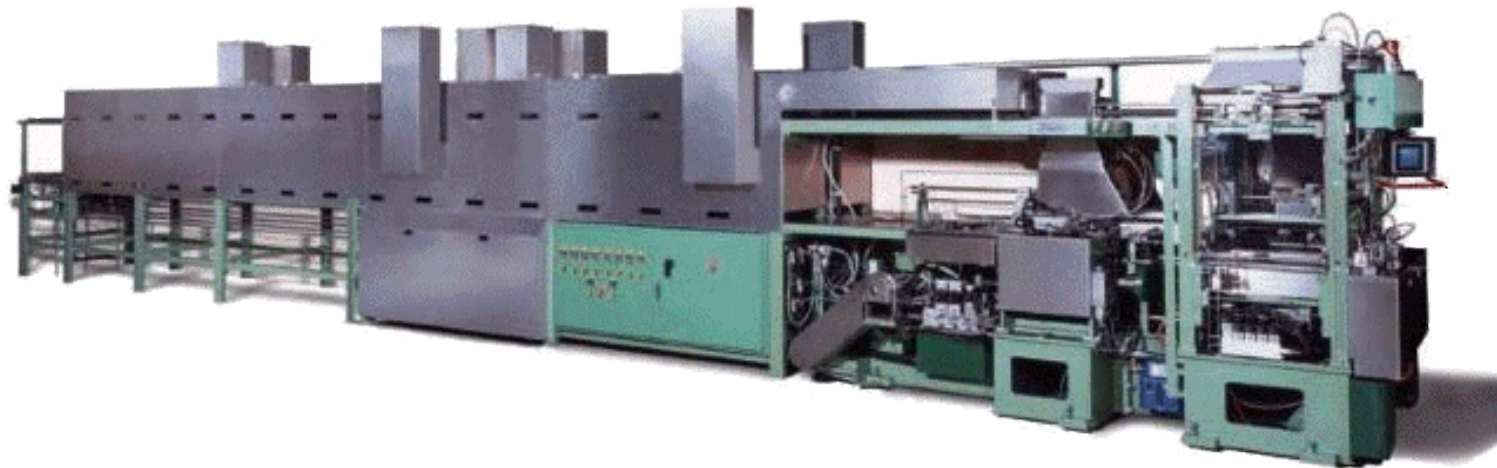

**72,000 – 81,000 / hr output, capsule sizes 00 – 5.**

**Full range of ancillary & accessory equipment + technology available including:**

- **gelatine colour mixing**
- **gelatine melting**
- **capsule sorting**
- **air conditioning**
- **advanced capsule / pin bar designs**
- **workshop design**
- **training from ex-multinational technical specialists**

## 5) SOFT GELATINE CAPSULE MANUFACTURE

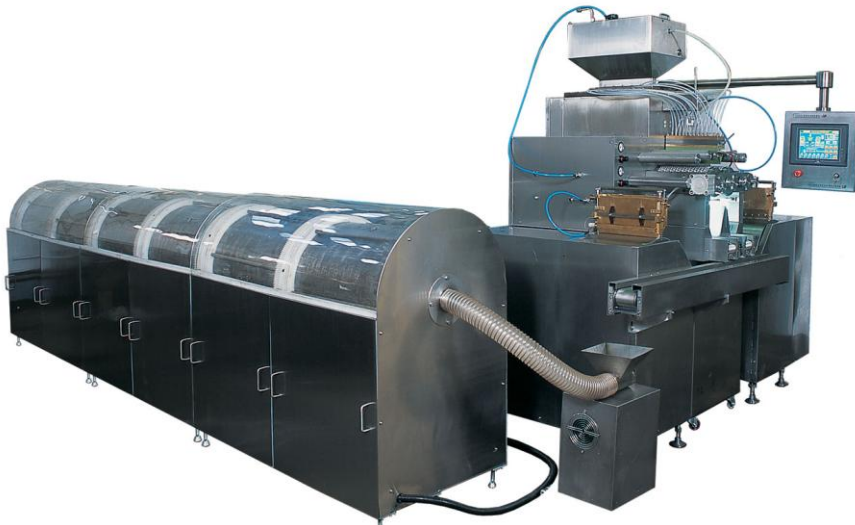

**5,000 – 200,000 / hr output range of machines, with integral tumble dryers + touch screen Siemens control panels.**

**Full range of accessory equipment + technology available including:**

- **fill mixers + mills**
- **gelatine colour mixing**
- **gelatine melters + holding tanks**
- **capsule sorting**
- **air conditioning**
- **advanced capsule die roll designs**
- **workshop design**
- **training from ex-mltinational technical specialists**
- **capsule formulations**

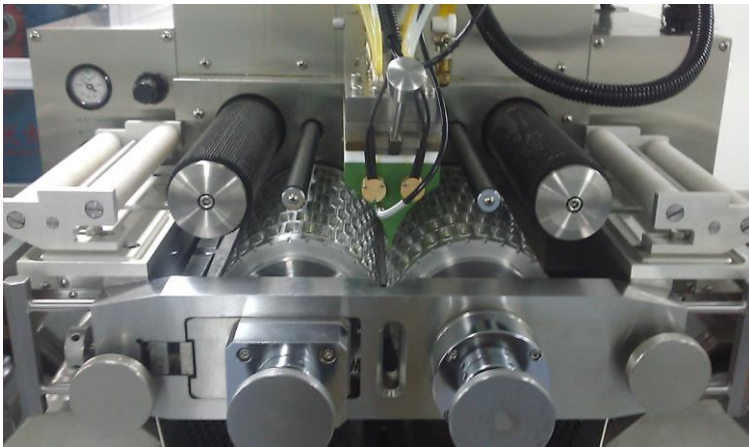



INTERPHARM TECHNOLOGIES LTD

## 6) TABLET / CAPSULE BOTTLE PACKING

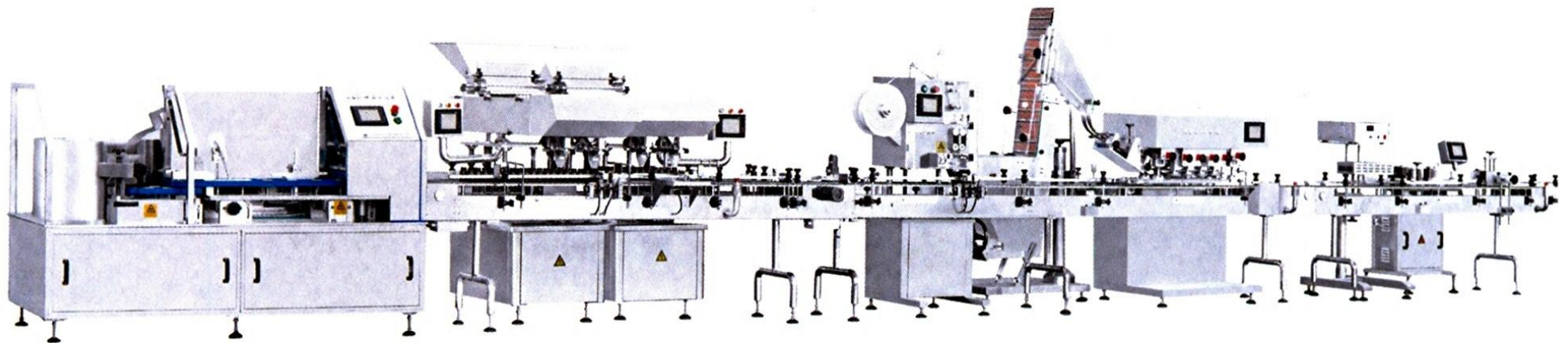

**Interpharm offers fully integrated systems for tablet / capsule filling into all types of plastic & glass bottle.  
Unscrambling, filling, cottoning, sealing, capping, labelling, & cartoning.  
Output speeds from 20 – 120 bottles / minute.**



## 7) TABLET / CAPSULE AUTOMATIC BLISTER PACKERS & CARTONERS

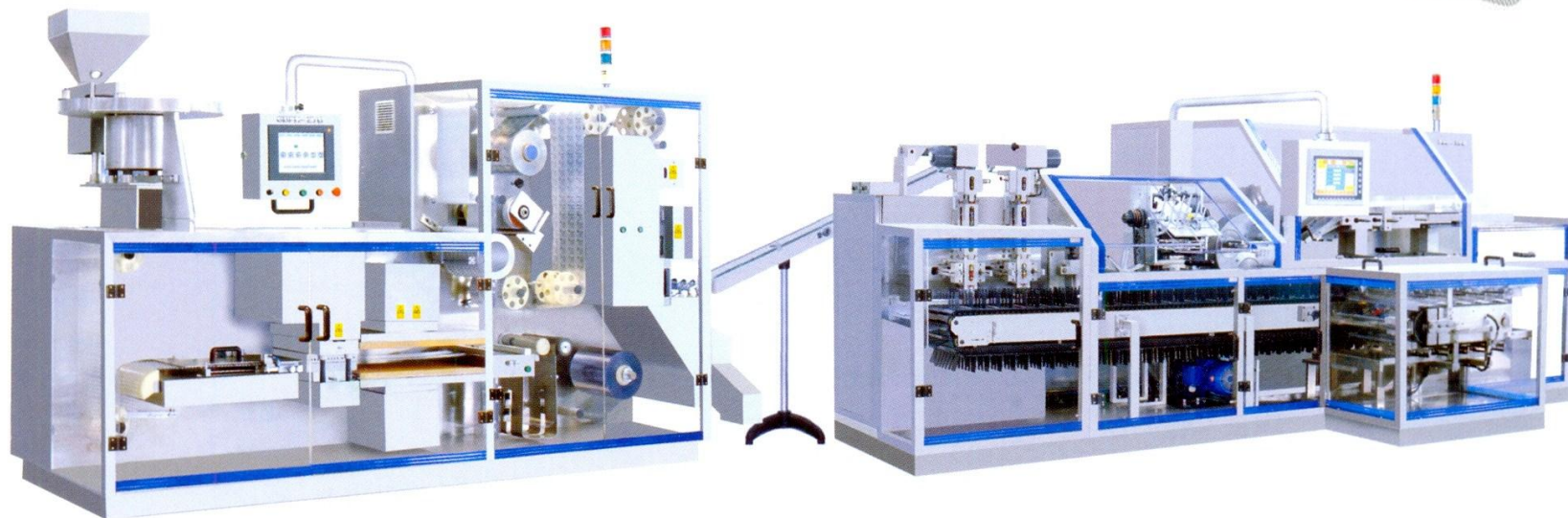

- **Wide range of PVC / ALU FOIL blister packers of output up to 600 blisters/minute.**
- **Advanced ALU / ALU blister machines.**
- **Full downstream line capabilities, with capping, labelling, cartoning, batch no. coding etc. Cartoners output up to 260/minute.**



## 8) LIQUID PRODUCT + STERILE MANUFACTURE

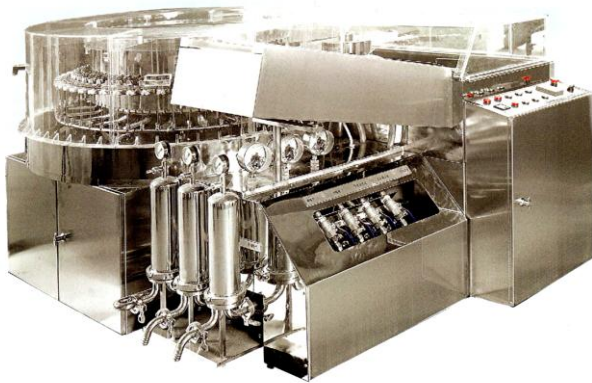

**There is a full range of washing & filling equipment + complete lines for all dosage forms:**

- **bottle liquid filling**
- **eye drops**
- **ampoules**

## INTERPHARM TECHNOLOGIES' SERVICE

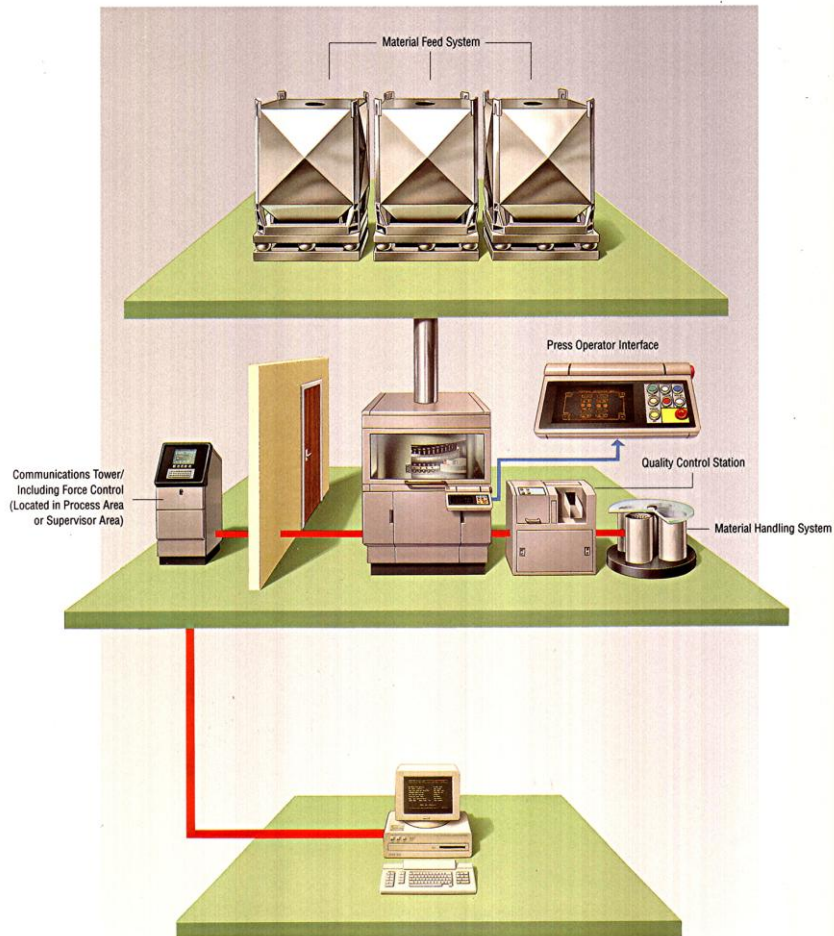

**INTERPHARM IS A UNIQUE PHARMACEUTICAL ORGANISATION – OFFERING OUR EUROPEAN EQUIPMENT & TECHNOLOGY COMBINED WITH OUR WIDE KNOWLEDGE OF THE EQUIPMENT & TECHNOLOGY AVAILABLE FROM ELITE SOURCES WORLD-WIDE.**

**IN ADDITION TO OUR PARTNERSHIP WITH THE STATE PHARMACEUTICAL ADMINISTRATION OF CHINA (SINOPHARM), WE ALSO WORK CLOSELY WITH GLOBAL PHARMACEUTICAL MULTINATIONALS & EXPERIENCED WESTERN INDUSTRY SPECIALISTS.**

**WE OFFER STATE OF THE ART EQUIPMENT & TECHNOLOGY COMBINED WITH CUTTING EDGE VALUE FOR MONEY.**

**INTERPHARM & OUR PARTNERS HAVE THE SCOPE TO SUPPLY FROM A SINGLE TABLET MACHINE TO A FULLY INTEGRATED RAW MATERIAL TO FINISHED PRODUCT INDUSTRIAL MANUFACTURING COMPLEX .**

**WE ALSO OFFER A NEW PRODUCT DEVELOPMENT & MARKETING DEVELOPMENT SERVICE.**

## **PHARMACEUTICAL FINISHED PRODUCTS**

**ADULT PREPARATIONS SHOWN – PAEDIATRIC PREPARATIONS AVAILABLE BY SPECIAL REQUEST  
OTHER PRODUCT TYPES AVAILABLE ON SPECIAL REQUEST**

### **ANTI-INFECTIVE / ANTI-BACTERIAL DRUGS**

#### **PENICILLINS**

**Amoxicillin 250 mg / 500 mg tablets or capsules**

**Ampicillin 250 mg / 500 mg tablets or capsules**

**Ampicillin Sodium 500 mg injection**

**Ampicillin + Cloxacillin 500 mg capsules**

**Benzylpenicillin (Penicillin G Sodium) 600 mg / 1200 mg injection**

**Cloxacillin 250 mg capsules**

**Cloxacillin 250 mg / 500 mg injection**

**Fortified Procaine Penicillin 0.4 / 1.0 / 3.0 / 4.0 miu injection**

**Penicillin G Procaine 1.0 miu / 3.0 miu injection**

**Penicillin G Benzathine 1.2 miu / 2.4 miu injection**

**Tri-Penicillin injection (0.6 miu benzathine penicillin : 0.3 miu parts benzylpenicillin potassium :  
0.3 miu parts procaine penicillin)**

**Phenoxymethylpenicillin (Penicillin V) 125 mg / 250 mg tablets or capsules**



**INTERPHARM HAVE SUPPLIED PHARMACEUTICAL  
EQUIPMENT + TECHNOLOGY GLOBALLY FOR  
THREE DECADES .**

**THROUGH OUR PARTNERSHIP WITH THE  
CHINESE STATE PHARMACEUTICAL  
ADMINISTRATION IN BEIJING, WE SUPPLY A  
COMPREHENSIVE RANGE OF ORAL & INJECTABLE  
MEDICINES, MANUFACTURED IN GMP, STATE OF  
THE ART PRODUCTION FACILITIES.**



## **CEPHALOSPORINS**

**Cephalexin 250 mg / 500 mg tablets or capsules**  
**Ceftriaxone Sodium 250 mg / 1.0 gm / 2.0 gm injection**  
**Cefotaxime Sodium 500 mg / 1.0 gm / 2.0 gm injection**

## **OTHER ANTIBACTERIAL DRUGS**

**Chloramphenicol 250 mg tablets or capsules**  
**Chloramphenicol Sodium Succinate 1.0 gm injection**  
**Co-trimoxazole (SMZ 400 mg + TMP 80 mg) tablets**  
**Doxycycline HCl 100 mg tablets or capsules**  
**Gentamycin Sulphate 80 mg / 2 ml injection**  
**Erythromycin Stearate 250 mg tablets or capsules**  
**Tetracycline HCl 250 mg tablets or capsules**

## **ANTI-RETROVIRAL DRUGS**

**AIDS tests – 96 kits + Reagents / carton**  
**Abacavir 600 mg + Lamivudine 300 mg tablets**  
**Abacavir Sulphate 100 ml / 240 ml solution in bottle**  
**Abacavir Sulphate 300mg tablets**  
**Didanosine 25 mg / 50 mg / 100mg / 150 mg / 200 mg / 250 mg / 400 mg tablets or capsules**  
**Efavirenz 50 mg / 100 mg / 200 mg / 300 mg / 400 mg 600 mg tablets or capsules**  
**Efavirenz 600mg + Lamivudine 300mg + DDI 250mg tablets**  
**Efavirenz 600mg + Lamivudine 300mg + DDI 400mg tablets**  
**Emtricitabine 200 mg capsules**  
**Indinavir Sulphate 400mg capsules**  
**Lamivudine 10mg/ml 100 ml / 200 ml syrup in bottle**





INTERPHARM TECHNOLOGIES LTD

**Lamivudine 150mg / 300 mg tablets**  
**Lamivudine 150mg + Stavudine 30mg tablets**  
**Lamivudine 150mg + Stavudine 40mg tablets**  
**Lamivudine 30mg + Stavudine 6mg + Nevirapine 50mg tablets**  
**Lamivudine 60mg + Stavudine 12mg + Nevirapine 100mg tablets**  
**Lamivudine 150mg + Stavudine 30mg + Nevirapine 200mg tablets**  
**Lamivudine 150mg + Stavudine 40mg + Nevirapine 200mg tablets**  
**Lamivudine 150mg + Zidovudine 300 mg + Efavirenz 600mg tablets**  
**Lamivudine 150mg + Zidovudine 300mg tablets**  
**Lamivudine 150mg + Zidovudine 300mg + Nevirapine 200mg tablets**  
**Lopinavir 133.3mg+ Ritonavir 33.3mg softgel capsules**  
**Nelfinavir 50mg/ml 100 ml syrup in bottle**  
**Nelfinavir Mesylate 250mg tablets**  
**Nevirapine 200mg tablets**  
**Nevirapine 50mg/5ml oral suspension in 100 ml bottle**  
**Ritonavir 100mg capsules**  
**Saquinavir 200mg capsules**  
**Stavudine 30mg / 40 mg capsules**  
**Tenofovir Disoproxil Fumarate 300mg tablets**  
**Zidovudine 100mg 250 mg / 300 mg tablets or capsules**  
**Zidovudine 50mg/5ml syrup in 100 ml bottle**

#### **ANTITUBERCULOSIS DRUGS**

**Ethambutol 400 mg tablets or capsules**  
**Ethambutol 400 mg / Isoniazide 150 mg tablets**  
**Isoniazide 100 mg / 300 mg tablets or capsules**  
**Pyrazinamide 500 mg tablets or capsules**  
**Rifampicin 150 mg / 300 mg tablets or capsules**



INTERPHARM TECHNOLOGIES LTD

**Rifampicin 300 mg / Isoniazide 150 mg tablets or capsules**  
**Rifampicin 120 mg / Isoniazide 50 mg / Pyrazinamide 300 mg tablets**  
**Rifampicin 300 mg / Isoniazide 75 mg / Pyrazinamide 400 mg tablets**  
**Rifampicin 150 mg / Isoniazide 75 mg / Pyrazinamide 400 mg / Ethambutol 275 mg kit**  
**Rifampicin 450 mg / Isoniazide 300 mg / Pyrazinamide 750 mg / Ethambutol 800 mg kit**  
**Thiacetazone 150 mg / Isoniazide 300 mg tablets**  
**Streptomycin Sulphate 1.0 gm injection**  
**Kanamycin Acid Sulphate 0.5 miu / 2 ml injection**  
**Ethionamide 125 mg / 250 mg tablets**

#### ANTIMALARIAL DRUGS

**Artesunate 50 mg tablets or capsules**  
**Mefloquine 250 mg tablets or capsules**  
**Chloroquine Phosphate 125 mg / 250 mg / 500 mg tablets**  
**Quinine Sulphate 200 mg / 300 mg tablets**  
**Sulfadoxine 500 mg / pyrimethamine 25 mg tablets**

#### CARDIOVASCULAR DRUGS

**Methyldopa 250 mg / 500 mg tablets**  
**Nifedipine Retard 20 mg tablets**  
**Captopril 12.5 mg / 25 mg / 50 mg tablets**  
**Streptokinase 250,000 iu / 750,000 iu injection**



## **GASTROINTESTINAL DRUGS**

**Oral Rehydration Salts 27.9 gm sachets**

## **CONTRACEPTIVES**

**Depot Medroxyprogesterone Acetate 100 mg / 200 mg 2ml Injection**  
**Oral Contraceptive Levonorgestrel 150 mcg / Ethinylestradiol 30 mcg tablets**  
**Oral Contraceptive 'OC35' Ethinylestradiol 35 mcg / Cyproterone Acetate 2mg tablets**

## **MISCELLANEOUS**

**Paracetamol 500 mg tablets**  
**Empty Hard Gelatine Capsules (Sizes 00; 0; 1; 2; 3; 4)**  
**Water for injection 5ml / 10 ml**  
**Propylthiouracil 50 mg / 100 mg tablets**  
**Ethylchloride Spray**  
**Flutamide 250 mg tablets**  
**Propofol (anaesthetic) 20 mg / ml X 20 ml injection**  
**Midazolam (sedative) 10 mg / 2ml; 10 mg / 5 ml injection**  
**Atracurium besylate (muscle relaxant) 10 mg / ml - 2.5 ml / 5 ml / 25 ml injection**  
**Vitamin / Mineral / Herbal / Oil Preparations as required in tablets, hard capsules, softgel capsules**

**Special formulations or other products on request**

**REPRESENTED HERE ARE ONLY A SMALL SELECTION OF THE THOUSANDS OF FORMULATIONS AVAILABLE THROUGH OUR RELATIONSHIP WITH THE CHINESE GOVERNMENT & THE WIDER INTERNATIONAL PHARMACEUTICAL INDUSTRY.**

**ALSO AVAILABLE ARE THE TECHNOLOGIES & FERMENTATION + REACTOR EQUIPMENT TO MANUFACTURE MOST IF NOT ALL PHARMACEUTICAL & NUTRACEUTICAL / VITAMIN RAW MATERIALS.**



***A LARGE SCALE ANTIBIOTIC FERMENTATION PLANT DESIGNED & SUPPLIED BY INTERPHARM'S PARTNER***





**Interpharm Technologies Ltd**

**St George's House**

**16 Atkins Close**

**Bradwell**

**Milton Keynes**

**Buckinghamshire**

**MK13 9HT**

**United Kingdom**

**Tel: +44 7951 555356**

**E-mail: [interpharmuk@gmail.com](mailto:interpharmuk@gmail.com)**